

8. Detailing for Economy

8.1 Detailing on Design Engineer's Drawings

It is in the design office that the potential economy of any steel structure is effectively determined. Judicious decisions on details at this stage can provide for simple, economic methods to be used at the fabrication stage.

The designer is faced with the problem that a different fabrication and erection technique could be favoured by each individual fabricator likely to tender for the project. It is a good idea at the outset for the designer to have some preliminary discussions with likely fabricators and steel detailers to check on latest techniques prevailing in the industry. From these discussions the design and detailing approach for the structure can be carried out with factors influencing economics firmly in mind.

In the normal course of events a steel structure passes through several separate stages involving design, detailing, fabrication and erection. With this in mind, it is important for designers to remember that a minimum of design detailing by them will assist towards economy, since the steel detailer is then left free to make the most efficient use of the particular fabricator's capabilities (Ref. 2.12). The need for this flexibility is often overlooked by designers in their anxiety to specify their requirements.

Such things as a fabricator's ability to fabricate large sub-assemblies in the shop and subsequently transport to site and erect them will obviously have a bearing on the design of connection types and therefore on the economy of the overall project. In this regard it must be stressed that a maximum of work done in the workshop will almost always produce better quality and more economical structures.

In the presentation of working drawings therefore, the basic key is 'communication' which normally takes place through a chain as illustrated in Figure 8.1.

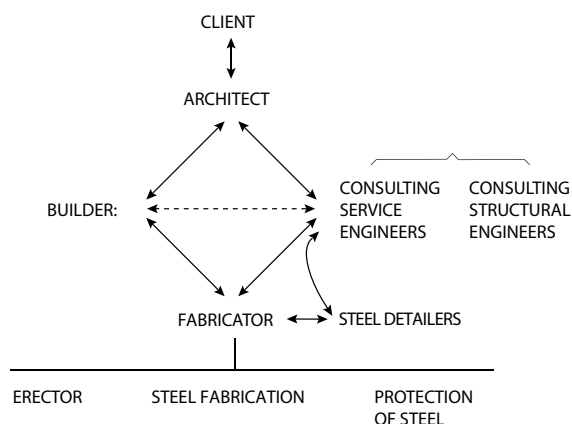

FIGURE 8.1: Chain of communication

The processes involved in the design can be summarised in the following sequence:

- Initial communication.
- Structural concept including consideration of connection types.
- Integrated design.
- Connection detailing.
- Framing plans.

The Engineer's structural framing plans must contain all the necessary information to enable the fabricator to have shop drawings prepared for the individual members, as well as the marking plans to identify each member for the erection phase.

Guidance for designers is provided by the Australian Institute of Steel Detailers Contract Documents Completion Checklists, Ref. 8.1.

The following discussion is intended to highlight aspects of the detailing of both members and connections to achieve economy in the overall fabrication and erection of structural elements.

As an additional consideration the use of ASI: Connections Design Guides – First Edition 2007 (Ref. 1.) will enable designers to specify standardised connections directly from the publication without detailing, and if necessary permit alternatives to be offered by the fabricator with the confidence of assured design capacity and behaviour.

8.2 Beams

8.2.1 GENERAL

The simplest and therefore the most economic beams in structures will be of rolled universal sections. Wherever possible, it will almost always prove more economic in one-off types of steel structures to use a universal section or welded beam section as a beam, even if a heavier solution results. The alternative fabrication of a three-plate girder introduces plate preparation, assembly and welding, the costs of which will generally exceed the cost of additional WB material in the rolled universal section or standard WB section, unless a vast amount of repetition is required.

8.2.2 PLATED SECTIONS

Where headroom limitations apply (distance from ceiling soffit to floor level), it may be necessary to consider plating a universal section of a limited depth instead of choosing a deeper beam. Here, the extra cost of supplying plates, assembling and welding causes the cost of the member to rise and a plated solution should only be used when a net saving in cost results compared to other feasible alternatives.

Attention to the detailing of the member will assist in keeping fabrication costs down. For example, selecting cover plate widths as shown in Figure 8.2 will allow the

8. Detailing for Economy

welding of both plates to the beam to be done in the downhand position without the need to turn the member during fabrication.

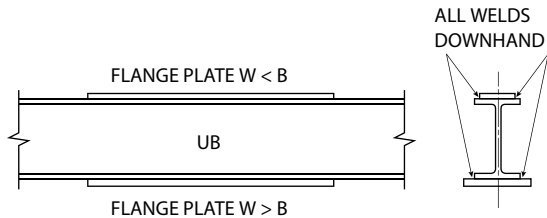

FIGURE 8.2: Plated sections

8.2.3 WEB PENETRATIONS IN BEAMS

Holes cut in the webs of beams to provide access for service ducts have proved to be very costly in the past due to uneconomic detailing. This is due to the fact that, traditionally, these openings have been compensated for by the provision of extensive stiffening systems around the openings (see Figure 8.3(a)).

The position of such openings in the beam length obviously has a major effect on the degree of stiffening required – openings near the centre of uniformly loaded beams will require little or no stiffening, while openings placed near the supports may require stiffening. An early dialogue between the structural engineer and the building services designer can lead to ducting being located in a favourable position structurally without detriment to service requirements.

Plain circular openings as shown in Figure 8.3(d) obviously represent the most economic solution. These can be cut by automatic means and result in minimum additional fabrication costs. If additional stiffening is required for round holes, it is most economic to use a pipe piece, fillet welded to the beam web (see Figure 8.3(c)).

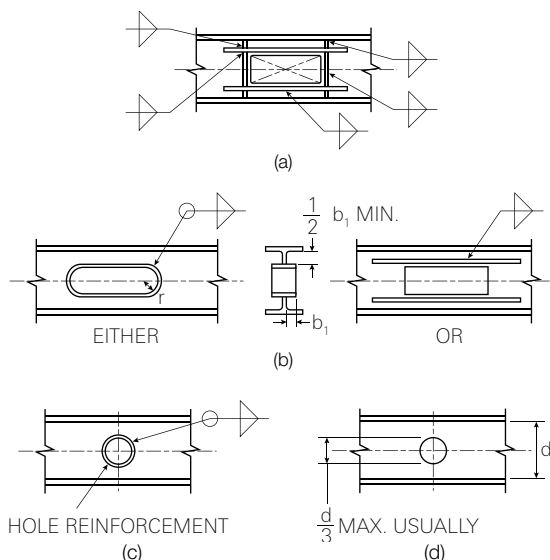

FIGURE 8.3: Web penetrations in beams (in descending order of cost, (d) being least costly)

Where rectangular holes cannot be avoided and stiffening is necessary, this can be economically accomplished by a web hole with half-pipe cuttings and make-up plates or, alternatively, simply reinforcing the beam web using square edge flat bars fillet welded to one side of the beam web as shown in Figure 8.3(b).

By judicious planning, the duct penetrations required in beams should be selected in position, size and shape to gain maximum economy in the fabrication of such beams.

8.2.4 CASTELLATED BEAMS

Castellated beams are fabricated by cutting a profiled line in the web of a universal beam – Figure 8.4. Circular profiles in lieu of the hexagonal profiles are also available from fabricators using computer controlled fabrication equipment. The beam halves are then offset longitudinally and the part webs welded on member centreline.

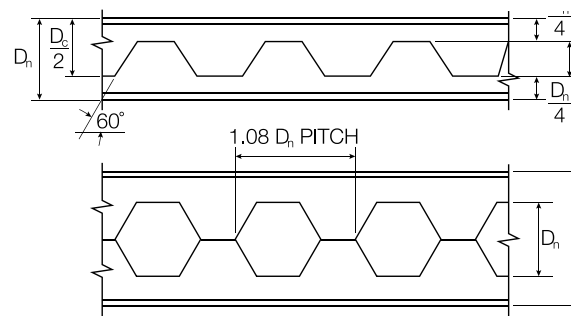

D_c = overall depth of castellated section
 D_n = nominal depth of original section
 D = actual depth of original section

$$D_c = D + \frac{D_n}{2}$$

Example:

original section = 530 UB 82
 $D_n = 530$ $D = 528$
 $D_c = 528 + 265 = 793$

FIGURE 8.4: Typical castellated beam geometry

The use of castellated beams in steel structures is often seen as a method of increasing beam strength while using the same mass of material. While many instances have been reported where savings have been effected, it must again be remembered that a fabrication cost has been introduced which could be larger than the saving made in material cost – depending upon the quantities required and the methods used.

The cost involved for this additional fabrication varies depending on the equipment available within individual fabrication shops. In some cases, problems can be encountered with distortion of the beam during cutting, thus requiring subsequent straightening of the members and adding further to the cost. In general, most fabricating shops are now well-equipped to undertake the fabrication of castellated beams, but designers should carefully

Economical Structural Steelwork

edited by

John Gardner

Fifth edition - 2009



AUSTRALIAN STEEL INSTITUTE

Contents

	Page		Page
1. Preliminary Considerations	1	6. Bolting	43
1.1 Introduction	1	6.1 Introduction	43
1.2 Factors influencing Framing Cost	1	6.2 Bolt Types	43
1.3 Integrated Design	2	6.3 Bolting Categories	43
2. General Factors Affecting Economy	3	6.4 Factors Affecting Bolting Economy	44
2.1 Steel Grades	3	6.5 Summary for Economic Bolting	45
2.2 Economy in use of Material	4	7. Welding	48
2.3 Fabrication	5	7.1 Introduction	48
2.4 Erection	7	7.2 Types of Welds	48
2.5 Surface Treatment	9	7.3 Welding Processes	50
2.6 Fire Resistance	11	7.4 Other Cost Factors	51
2.7 Specifications	12	7.5 Economical Design and Detailing	52
3. Framing Concepts and Connection Types	16	8. Detailing for Economy	56
3.1 Introduction	16	8.1 Detailing on Design Engineer's Drawings	56
3.2 Connection Types	16	8.2 Beams	56
3.3 Basic Framing Systems	19	8.3 Columns	59
3.4 Cost and Framing System	23	8.4 Trusses	63
3.5 Framing Details	24	8.5 Portal Frames	65
3.6 Conclusion	26	8.6 Connection Detailing	66
4. Industrial Buildings	27	9. References & Further Reading	75
4.1 Introduction	27	10. Standards	77
4.2 Warehouse and Factory Buildings	27		
4.3 Large Span Storage Buildings	34		
4.4 Heavy Industrial Structures	34		
5. Commercial Buildings	36		
5.1 Introduction	36		
5.2 Low-Rise Commercial Buildings	36		
5.3 High-Rise Commercial Buildings	37		
5.4 Floor Support Systems	40		
5.5 Composite Construction	41		
5.6 Summary	42		

